

5100 Series Probes

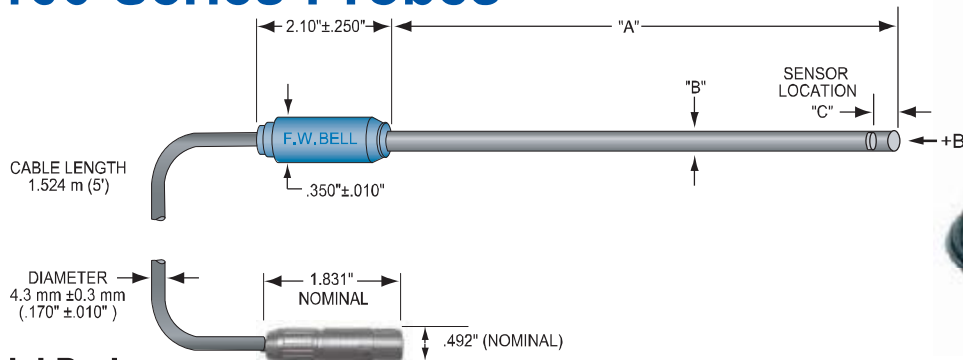

Axial Probes

Model	A ±.063"	B	C	Stem Material	Corrected Linearity	Sensitivity	Active area	Operating temp. range	Temp. stability (typical)		Frequency Response
									Zero	Calibrate	
SAD18-1902	2"	0.187" ±.003"	0.010" (NOMINAL)	RIGID PHENOLIC	0.5%/30kG	1X	0.015" DIA. (NOM)	0°C to +75°C	±0.300 Gauss / °C	-0.05% % / °C	DC to 20kHz
SAD18-1904	4"										DC to 10kHz
SAH17-1902	2"				DC to 10kHz						
SAH17-1904	4"				DC to 10kHz						

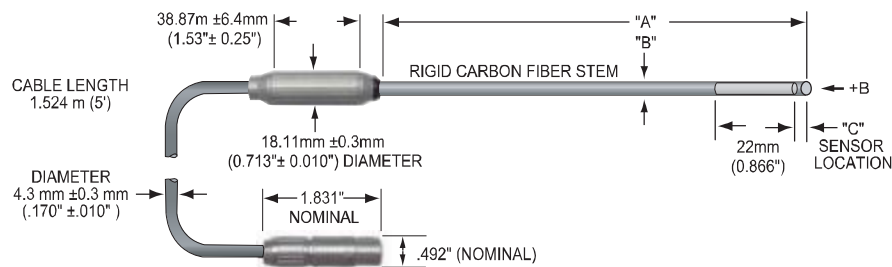

Low Field Axial Probes

Model	A ±.063"	B	C	Stem Material	Corrected Linearity	Sensitivity	Active area	Operating temp. range	Temp. stability (typical)		Frequency Response
									Zero	Calibrate	
MOS51-3204	4"	0.285" ±0.006"	0.050" (NOMINAL)	RIGID PHENOLIC	0.75%/1G	1X	0.866" (NOM)	0°C to +75°C	±0.02 mG / °C	-0.001 % / °C	DC to 700Hz (-3dB)

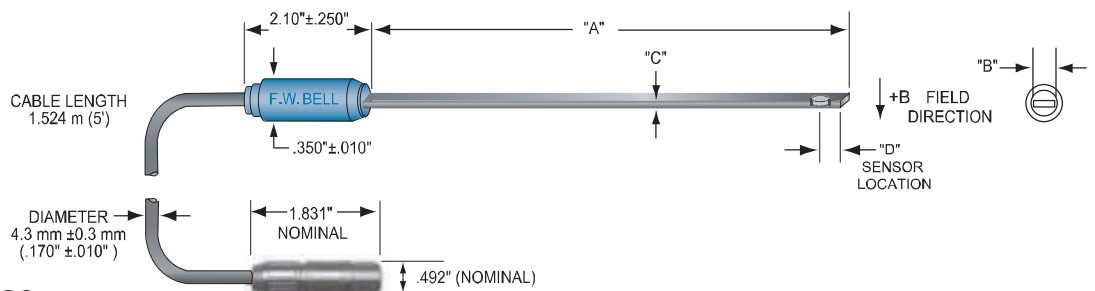

Transverse Probes

Model	A ±.063"	B	C	D	Material	Corrected Linearity	Sensitivity	Active area	Operating temp. range	Temp. stability (typical)		Frequency Response
										Zero	Calibrate	
STD18-0402	2"	0.158" ±.004"	0.045" ±.004"	0.0335" (NOMINAL)	Polypropylene	0.5%/30kG	1X	0.015" DIA. (NOM)	0°C to +75°C	±0.300 Gauss / °C (typical)	-0.05% % / °C (typical)	DC to 20kHz
STD18-0404	4"											DC to 10kHz
STH17-0402	2"				DC to 10kHz							
STH17-0404	4"				DC to 10kHz							
HTH17-0604	4"	0.180" ±.004"	0.060" +.000" -.004"	0.030" (NOMINAL)	ALUMINUM 3003 3/4 FH	1.0%/20KG	0.025" DIA (NOM.)	±0.200 Gauss / °C	-0.1 % / °C	DC only	DC to 10kHz	
HTD18-0604	4"					0.5%/30kG					DC to 20kHz	
STB1X-0201	1"	.050" ±.005"	.020" MAX	0.030" (NOMINAL)	KAPTON	1.0%/10KG					DC only	

Note: Due to continuous process improvement, specifications subject to change without notice.

** Prior to late 2006 Transverse Probe Stems were rigid glass epoxy, .150 x .040".